

Warming drawer Silver

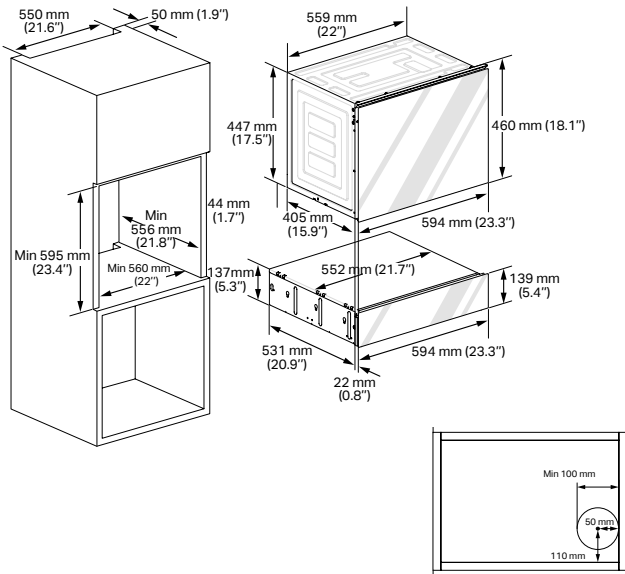

Installation of the compact oven with warming drawer



Installation in a high cabinet

There must be a gap of minimum 10 mm (0.4") between the rear of the installed oven and the connecting wall. Kitchen cabinet in contact with the oven must be heat resistant up to 90 °C, and close units fronts up to at least 70 °C.

Notes

Remove the back wall of the installation cabinet. If it is difficult to remove the back wall, make a hole at least 100 mm (3.94") in diameter that the drawer power cord can protrude on the back wall.

Ventilation

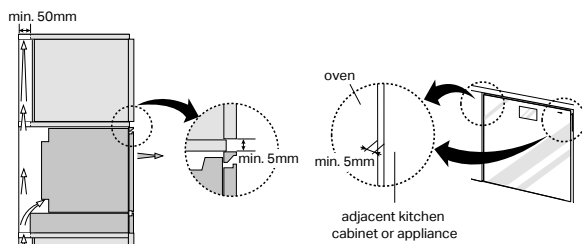

Notes

For correct ventilation, the ventilation opening of 50 mm (1.97") should be required between the back wall and the floor of the installation cabinet, the ventilation gap of 5 mm (1.97") is required between the oven top rim and the furniture lower rim, and between the oven both sides rim and the cabinet. These openings must not be closed in any way. Therefore ensure that the sides are not touching the front edges of the housing. Connect the oven to the power supply.

SKSWD2421MS

General properties	EAN: 8806084782526
Finish	Silver
Temperature levels	40°C - 55°C - 70°C - 80°C
Operating indicator	●
Pre-heat dishes	●
Keep warm	●
Proof	●
Defrost	●
Cooking at low temperature	●
Technical Specifications	
Cavity size	19 l
Power consumption kW	0.45
Circuit breaker	20 A
Required power supply	230 V, 50 Hz
Plug type	F Type
Power supply type	Electrical
Overall width	594 mm
Overall height	139 mm
Overall depth	531 mm